



PIÑONES EN FUNDICION PARA CADENAS - DIN 8187 - ISO 606

CAST IRON SPROCKETS FOR ROLLER CHAINS

3/8" x 7/32"

9,525 x 5,72 mm
Rodillo 6,35 mm
06B - 1 - 2 - 3

B1	B2	B3	b1	C	r3
5,3	15,4	25,6	5,2	1	10

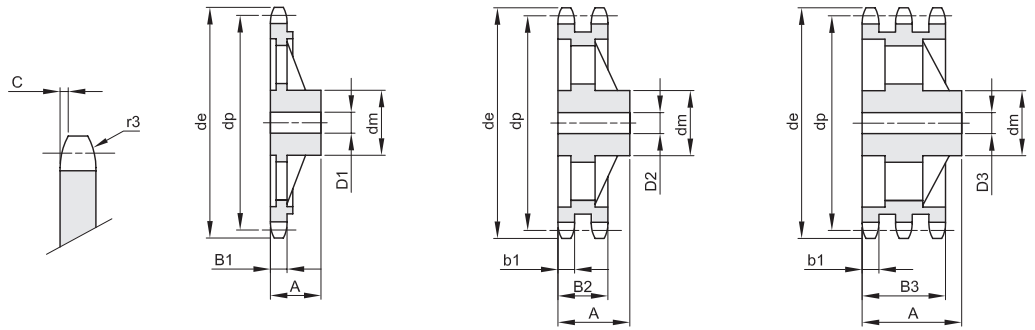

Material Fundición EN-GJL-200

Z	de	dp	simple				doble				triple				
			dm	D1	A	Kg.	dm	D2	A	Kg.	dm	D3	A	Kg.	
38	119,0	115,34	70	20	32	1,12									
45	141,1	136,54	70	20	32	1,30	80	20	40	2,06	90	24	56	3,56	
57	177,5	172,91	70	20	32	1,55	80	20	40	2,30	90	24	56	3,97	
76	235,1	230,49	70	20	35	2,00	80	20	40	3,02	100	24	56	4,52	
95	292,7	288,08	80	20	40	3,83	90	20	45	4,68	100	24	56	6,12	
114	350,3	345,68	80	20	40	4,05	95	20	45	5,90	100	24	56	7,45	

1/2" x 5/16"

12,7 x 7,75 mm
Rodillo 8,51 mm
08B - 1 - 2 - 3

B1	B2	B3	b1	C	r3
7,2	21	34,9	7	1,3	13

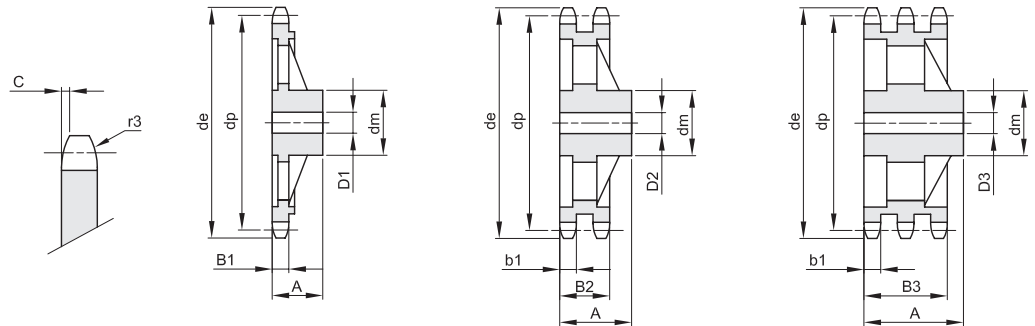

Material Fundición EN-GJL-200

Z	de	dp	simple				doble				triple			
			dm	D1	A	Kg.	dm	D2	A	Kg.	dm	D3	A	Kg.
38	158,6	153,80	70	24	40	1,56	90	24	50	3,15	100	24	60	4,45
45	188,6	182,07	70	24	40	1,95	90	24	50	3,56	100	24	60	5,85
57	237,1	230,54	70	24	40	2,46	90	24	50	4,00	100	24	60	6,28
76	313,9	307,33	80	24	40	4,20	100	24	56	6,35	100	24	60	8,60
95	390,7	384,11	80	24	45	5,45	100	24	56	8,00	120	24	67	11,90
114	467,4	460,90	80	24	45	8,35	100	24	63	11,90				



PIÑONES EN FUNDICIÓN PARA CADENAS - DIN 8187 - ISO 606

CAST IRON SPROCKETS FOR ROLLER CHAINS

5/8" x 3/8"

15,875 x 9,65 mm
Rodillo 10,16 mm
10B - 1 - 2 - 3

B1	B2	B3	b1	C	r3
9,1	25,5	42,1	9	1,6	16

Material Fundición EN-GJL-200

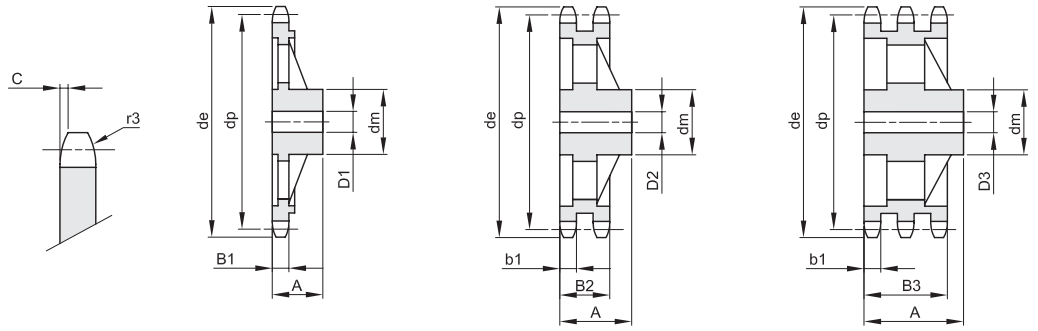

Z	de	dp	simple				doble				triple			
			dm	D1	A	Kg.	dm	D2	A	Kg.	dm	D3	A	Kg.
38	199,1	192,24	80	24	40	2,32	100	30	50	4,56	100	32	60	6,50
45	236,0	227,58	80	24	40	2,88	100	30	50	4,93	100	32	60	7,04
57	296,6	288,18	90	24	45	4,30	100	30	56	6,50	100	32	63	8,00
76	392,5	384,16	90	24	50	7,00	100	30	63	9,10	110	35	67	12,00
95	488,5	480,14	100	24	56	10,65	110	30	63	12,60	125	35	70	19,40
114	584,5	576,13	100	24	56	14,50	125	30	70	17,80	125	35	80	24,00

3/4" x 7/16"

19,05 x 11,68 mm
Rodillo 12,07 mm
12B - 1 - 2 - 3

B1	B2	B3	b1	C	r3
11,1	30,3	49,8	10,8	2	19

Material Fundición EN-GJL-200

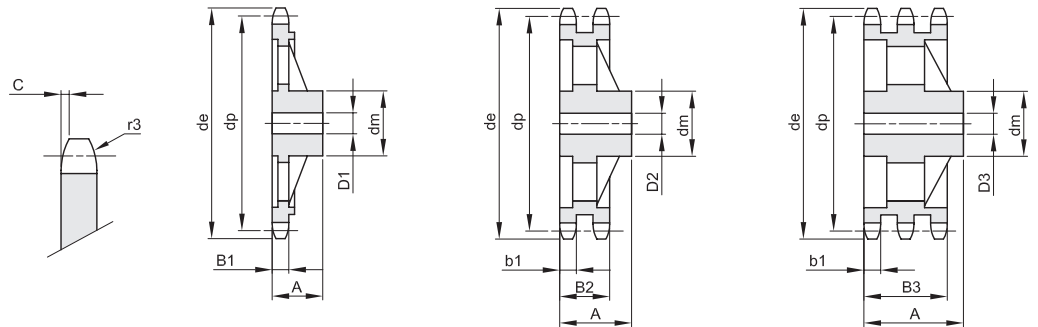

Z	de	dp	simple				doble				triple			
			dm	D1	A	Kg.	dm	D2	A	Kg.	dm	D3	A	Kg.
38	238,9	230,69	100	24	56	4,75	110	25	63	7,50	115	30	70	10,00
45	283,2	273,10	100	24	56	5,90	110	30	63	8,30	140	30	70	13,30
57	355,9	345,81	100	30	56	6,45	120	30	63	10,30	140	40	70	15,25
76	471,1	460,99	100	30	56	12,30	135	30	63	15,20	160	40	75	27,20
95	586,2	576,17	100	30	65	15,40	135	30	70	20,20	170	40	82	36,40
114	701,4	691,36	100	30	65	24,80M	135	45	70	30,40	170	50	82	41,10



PIÑONES EN FUNDICION PARA CADENAS - DIN 8187 - ISO 606

CAST IRON SPROCKETS FOR ROLLER CHAINS

1" x 17,02 mm

25,4 x 17,02 mm
Rodillo 15,88 mm
16B - 1 - 2 - 3

B1 B2 B3 b1 C r3

16,2 47,7 79,6 15,8 2,5 26

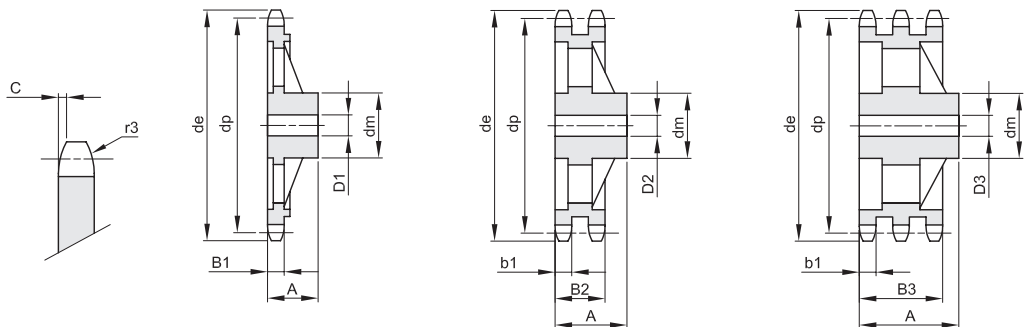

Material Fundición EN-GJL-200

Z	de	dp	simple				doble				triple			
			dm	D1	A	Kg.	dm	D2	A	Kg.	dm	D3	A	Kg.
38	319,2	307,59	110	30	65	8,26	140	40	75	16,45	160	45	100	25,40
45	377,9	364,12	125	30	70	10,75	150	40	75	19,20	160	45	100	33,60
57	474,9	461,07	125	35	70	12,90	170	40	90	29,50	180	45	100	44,70
76	628,4	614,65	140	35	80	24,70	175	40	95	46,30	200	45	110	63,10
95	782,0	768,22	140	40	80	32,00	175	45	95	53,00	200	50	110	77,00
114	935,6	921,81	150	40	80	45,50	180	45	95	74,00	200	50	115	97,00

1"1/4 x 3/4"

31,75 x 19,56 mm
Rodillo 19,05 mm
20B - 1 - 2 - 3

B1 B2 B3 b1 C r3

18,5 54,6 91 18,2 3,5 32

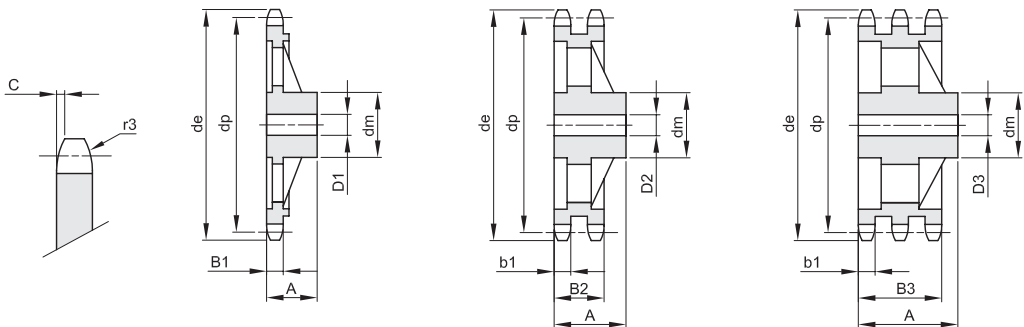

Material Fundición EN-GJL-200

Z	de	dp	simple				doble				triple			
			dm	D1	A	Kg.	dm	D2	A	Kg.	dm	D3	A	Kg.
38	399,4	384,49	125	35	70	12,30	140	45	90	24,80	180	50	115	52,00
57	592,3	576,36	135	40	80	25,60	170	50	100	43,00	180	50	130	71,50
76	784,3	768,32	140	50	90	29,10	180	50	110	62,50	200	50	140	115,00



PIÑONES EN FUNDICION PARA CADENAS - DIN 8187 - ISO 606

CAST IRON SPROCKETS FOR ROLLER CHAINS

1"1/2 x 1"

38,1 x 25,4 mm
Rodillo 25,4 mm
24B - 1 - 2 - 3

B1 B2 B3 b1 C r3

24,1 72 120,3 23,6 4 38

Material Fundición EN-GJL-200

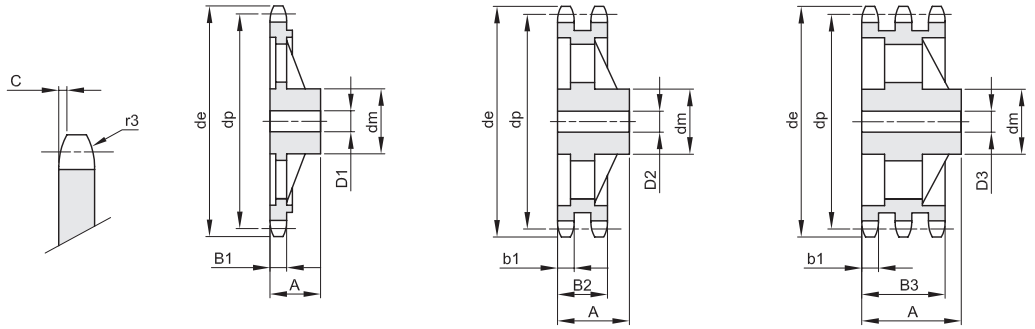

Z	de	dp	simple				doble				triple			
			dm	D1	A	Kg.	dm	D2	A	Kg.	dm	D3	A	Kg.
38	476,5	461,39	140	45	90	21,80	180	45	100	42,20	200	50	150	42,50
57	707,5	691,63	160	45	100	46,20	200	50	110	72,70	200	55	150	119,40
76	939,0	921,98	180	45	100	63,60	220	55	120	125,00				

