



POLEAS DENTADAS PARA CORREAS HTD®

HTD® TIMING BELT PULLEYS

3M

PASO 3 mm
PARA CORREA ANCHO 9 mm

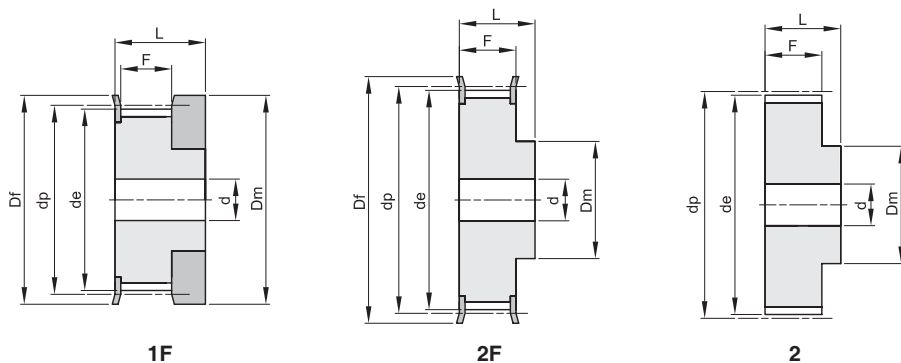

Material: Aluminio UNI 9006 - T6 (Al)

codigo	tipo	material	dientes	dp	de	Df	Dm	Di	F	L	d	n° guia	Kg.
10 3M 09	1F	Al	10	9,55	8,79	13,0	12,0		10,2	17,5		100	0,01
12 3M 09	1F	Al	12	11,46	10,70	15,0	15,0		10,2	17,5		101	0,01
14 3M 09	1F	Al	14	13,37	12,61	16,0	16,0		10,2	17,5		102	0,01
15 3M 09	1F	Al	15	14,32	13,56	18,0	17,5		10,2	17,5		104	0,01
16 3M 09	2F	Al	16	15,28	14,52	18,0	10,0		12,8	20,6	4	104	0,01
18 3M 09	2F	Al	18	17,19	16,43	19,5	11,0		12,8	20,6	6	105	0,01
20 3M 09	2F	Al	20	19,10	18,34	23,0	13,0		12,8	20,6	6	107	0,01
21 3M 09	2F	Al	21	20,05	19,29	25,0	14,0		12,8	20,6	6	108	0,01
22 3M 09	2F	Al	22	21,01	20,25	25,0	14,0		12,8	20,6	6	108	0,01
24 3M 09	2F	Al	24	22,92	22,16	25,0	14,0		12,8	20,6	6	108	0,02
26 3M 09	2F	Al	26	24,83	24,07	28,0	16,0		12,8	20,6	6	109	0,02
28 3M 09	2F	Al	28	26,74	25,98	32,0	18,0		12,8	20,6	6	110	0,02
30 3M 09	2F	Al	30	28,65	27,89	32,0	20,0		12,8	20,6	6	110	0,03
32 3M 09	2F	Al	32	30,56	29,80	36,0	22,0		12,8	20,6	6	111	0,03
36 3M 09	2F	Al	36	34,38	33,62	38,0	26,0		13,4	22,2	6	112	0,05
40 3M 09	2F	Al	40	38,20	37,44	42,0	28,0		13,4	22,2	6	113	0,06
44 3M 09	2F	Al	44	42,02	41,26	48,0	33,0		13,4	22,2	6	114	0,07
48 3M 09	2	Al	48	45,84	45,08		33,0		13,4	22,2	8		0,11
60 3M 09	2	Al	60	57,30	56,54		33,0		13,4	22,2	8		0,11
72 3M 09	2	Al	72	68,76	68,00		33,0		13,4	22,2	8		0,15



POLEAS DENTADAS PARA CORREAS HTD®

HTD® TIMING BELT PULLEYS

3M

PASO 3 mm

PARA CORREA ANCHO 15 mm

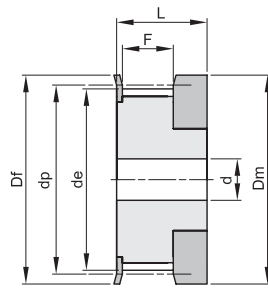

1F

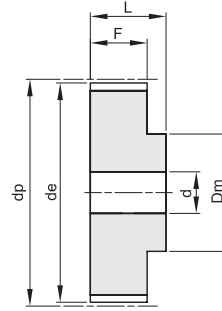

2

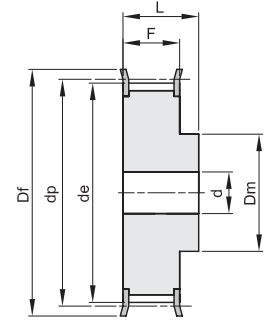

2F

Material: Aluminio UNI 9006 - T6 (Al)

codigo	tipo	material	dientes	dp	de	Df	Dm	Di	F	L	d	n° guia	Kg.
10 3M 15	1F	Al	10	9,55	8,79	13,0	12,0		17,0	26,0		100	0,01
12 3M 15	1F	Al	12	11,46	10,70	15,0	15,0		17,0	26,0		101	0,01
14 3M 15	1F	Al	14	13,37	12,61	16,0	16,0		17,0	26,0		102	0,01
15 3M 15	1F	Al	15	14,32	13,56	18,0	17,5		17,0	26,0		104	0,01
16 3M 15	2F	Al	16	15,28	14,52	18,0	10,0		19,5	26,0	4	104	0,01
18 3M 15	2F	Al	18	17,19	16,43	19,5	11,0		19,5	26,0	6	105	0,01
20 3M 15	2F	Al	20	19,10	18,34	23,0	13,0		19,5	26,0	6	107	0,01
21 3M 15	2F	Al	21	20,05	19,29	25,0	14,0		19,5	26,0	6	108	0,02
22 3M 15	2F	Al	22	21,01	20,25	25,0	14,0		19,5	26,0	6	108	0,02
24 3M 15	2F	Al	24	22,92	22,16	25,0	14,0		19,5	26,0	6	108	0,02
26 3M 15	2F	Al	26	24,83	24,07	28,0	16,0		19,5	26,0	6	109	0,03
28 3M 15	2F	Al	28	26,74	25,98	32,0	18,0		19,5	26,0	6	110	0,03
30 3M 15	2F	Al	30	28,65	27,89	32,0	20,0		19,5	26,0	6	110	0,04
32 3M 15	2F	Al	32	30,56	29,80	36,0	22,0		19,5	26,0	6	111	0,04
36 3M 15	2F	Al	36	34,38	33,62	38,0	26,0		20,0	30,0	6	112	0,06
40 3M 15	2F	Al	40	38,20	37,44	42,0	28,0		20,0	30,0	6	113	0,08
44 3M 15	2F	Al	44	42,02	41,26	48,0	33,0		20,0	30,0	6	114	0,10
48 3M 15	2	Al	48	45,84	45,08		33,0		20,0	30,0	8		0,10
60 3M 15	2	Al	60	57,30	56,54		33,0		20,0	30,0	8		0,15
72 3M 15	2	Al	72	68,76	68,00		33,0		20,0	30,0	8		0,21



POLEAS DENTADAS PARA CORREAS HTD®

HTD® TIMING BELT PULLEYS

5M

PASO 5 mm

PARA CORREA ANCHO 9 mm

Material: Acero (St)
Material: Aluminio UNI 9006 - T6 (Al)

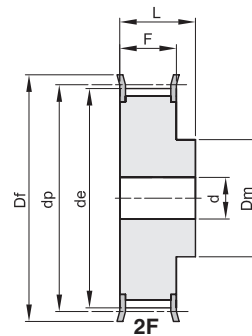
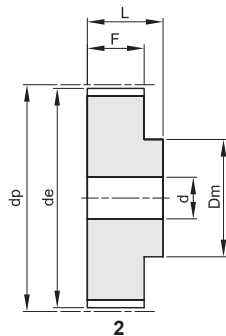

codigo	tipo	material	dientes	Dp	de	Df	Dm	Di	F	L	d	n° guia	Kg.
12 5M 09	2F	St	12	19,10	17,96	23	12,5		14,5	20,0	6	202	0,03
14 5M 09	2F	St	14	22,28	21,14	25	13,5		14,5	20,0	6	203	0,04
15 5M 09	2F	St	15	23,87	22,73	28	16,0		14,5	20,0	6	204	0,05
16 5M 09	2F	St	16	25,46	24,32	28	16,5		14,5	20,0	6	204	0,06
18 5M 09	2F	St	18	28,65	27,51	32	20,0		14,5	20,0	6	205	0,07
20 5M 09	2F	St	20	31,83	30,69	36	23,0		14,5	22,5	6	206	0,10
21 5M 09	2F	St	21	33,42	32,28	38	24,0		14,5	22,5	6	207	0,12
22 5M 09	2F	St	22	35,01	33,87	38	25,5		14,5	22,5	6	207	0,13
24 5M 09	2F	St	24	38,20	37,06	42	27,0		14,5	22,5	6	208	0,15
26 5M 09	2F	St	26	41,38	40,24	44	30,0		14,5	22,5	6	209	0,18
28 5M 09	2F	St	28	44,56	43,42	48	30,5		14,5	22,5	6	210	0,21
30 5M 09	2F	St	30	47,75	46,60	51	35,0		14,5	22,5	6	211	0,25
32 5M 09	2F	St	32	50,93	49,79	54	38,0		14,5	22,5	8	212	0,28
36 5M 09	2F	St	36	57,30	56,16	60	38,0		14,5	22,5	8	214	0,33
40 5M 09	2F	St	40	63,66	62,52	71	38,0		14,5	22,5	8	217	0,42
44 5M 09	2	Al	44	70,03	68,89		38,0		14,5	25,5	8		0,17
48 5M 09	2	Al	48	76,39	75,25		45,0		14,5	25,5	8		0,18
60 5M 09	2	Al	60	95,49	94,35		45,0		14,5	25,5	8		0,23
72 5M 09	2	Al	72	114,59	113,45		45,0		14,5	25,5	8		0,42



POLEAS DENTADAS PARA CORREAS HTD®

HTD® TIMING BELT PULLEYS

5M

PASO 5 mm

PARA CORREA ANCHO 15 mm

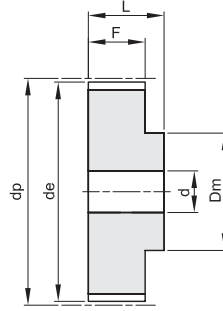

2

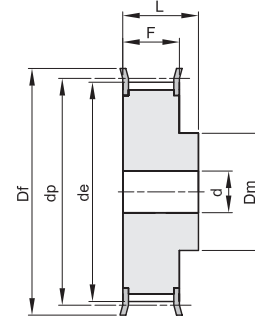

2F

Material: Acero (St)
Material: Aluminio UNI 9006 - T6 (Al)

codigo	tipo	material	dientes	dp	de	Df	Dm	Di	F	L	d	n° guia	Kg.
12 5M 15	2F	St	12	19,10	17,96	23	12,5		20,5	26	6	202	0,03
14 5M 15	2F	St	14	22,28	21,14	25	13,5		20,5	26	6	203	0,04
15 5M 15	2F	St	15	23,87	22,73	28	16,0		20,5	26	6	204	0,05
16 5M 15	2F	St	16	25,46	24,32	28	16,5		20,5	26	6	204	0,06
18 5M 15	2F	St	18	28,65	27,51	32	20,0		20,5	26	6	205	0,09
20 5M 15	2F	St	20	31,83	30,69	36	23,0		20,5	26	6	206	0,12
21 5M 15	2F	St	21	33,42	32,28	38	24,0		20,5	26	6	207	0,14
22 5M 15	2F	St	22	35,01	33,87	38	25,5		20,5	26	6	207	0,15
24 5M 15	2F	St	24	38,20	37,06	42	27,0		20,5	28	6	208	0,19
26 5M 15	2F	St	26	41,38	40,24	44	30,0		20,5	28	6	209	0,23
28 5M 15	2F	St	28	44,56	43,42	48	30,5		20,5	28	6	210	0,26
30 5M 15	2F	St	30	47,75	46,60	51	35,0		20,5	28	6	211	0,32
32 5M 15	2F	St	32	50,93	49,79	54	38,0		20,5	28	8	212	0,35
36 5M 15	2F	St	36	57,30	56,16	60	38,0		20,5	28	8	214	0,43
40 5M 15	2F	St	40	63,66	62,52	71	38,0		20,5	28	8	217	0,52
44 5M 15	2	Al	44	70,03	68,89		38,0		20,5	30	8		0,23
48 5M 15	2	Al	48	76,39	75,25		38,0		20,5	30	8		0,29
60 5M 15	2	Al	60	95,49	94,35		50,0		20,5	30	8		0,30
72 5M 15	2	Al	72	114,59	113,45		50,0		20,5	30	8		0,59



POLEAS DENTADAS PARA CORREAS HTD®

HTD® TIMING BELT PULLEYS

5M

PAS 5 mm

PARA CORREA ANCHO 25 mm

Material: Acero (St)

Material: Aluminio UNI 9006 - T6 (Al)

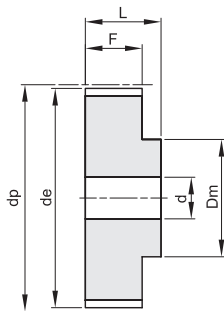

2

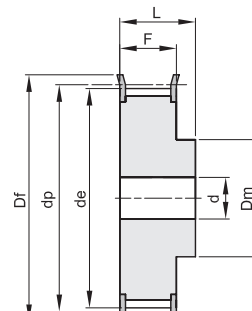

2F

codigo	tipo	material	dientes	dp	de	Df	Dm	Di	F	L	d	n° guia	Kg.
12 5M 25	2F	St	12	19,10	17,96	23	12,5		30,5	36	6	202	0,05
14 5M 25	2F	St	14	22,28	21,14	25	13,5		30,5	36	6	203	0,08
15 5M 25	2F	St	15	23,87	22,73	28	16,0		30,5	36	6	204	0,09
16 5M 25	2F	St	16	25,46	24,32	28	16,5		30,5	36	6	204	0,11
18 5M 25	2F	St	18	28,65	27,51	32	20,0		30,5	36	6	205	0,13
20 5M 25	2F	St	20	31,83	30,69	36	23,0		30,5	36	6	206	0,17
21 5M 25	2F	St	21	33,42	32,28	38	24,0		30,5	38	6	207	0,20
22 5M 25	2F	St	22	35,01	33,87	38	25,5		30,5	38	6	207	0,22
24 5M 25	2F	St	24	38,20	37,06	42	27,0		30,5	38	6	208	0,26
26 5M 25	2F	St	26	41,38	40,24	44	30,0		30,5	38	6	209	0,32
28 5M 25	2F	St	28	44,56	43,42	48	30,5		30,5	38	6	210	0,37
30 5M 25	2F	St	30	47,75	46,60	51	35,0		30,5	38	6	211	0,42
32 5M 25	2F	St	32	50,93	49,79	54	38,0		30,5	38	8	212	0,48
36 5M 25	2F	St	36	57,30	56,16	60	38,0		30,5	38	8	214	0,59
40 5M 25	2F	St	40	63,66	62,52	71	38,0		30,5	38	8	217	0,75
44 5M 25	2	Al	44	70,03	68,89		38,0		30,5	40	8		0,32
48 5M 25	2	Al	48	76,39	75,25		38,0		30,5	40	8		0,28
60 5M 25	2	Al	60	95,49	94,35		50,0		30,5	40	8		0,44
72 5M 25	2	Al	72	114,59	113,45		50,0		30,5	40	8		0,85



POLEAS DENTADAS PARA CORREAS HTD®

HTD® TIMING BELT PULLEYS

8M

PASO 8 mm

PARA CORREA ANCHO 20 mm

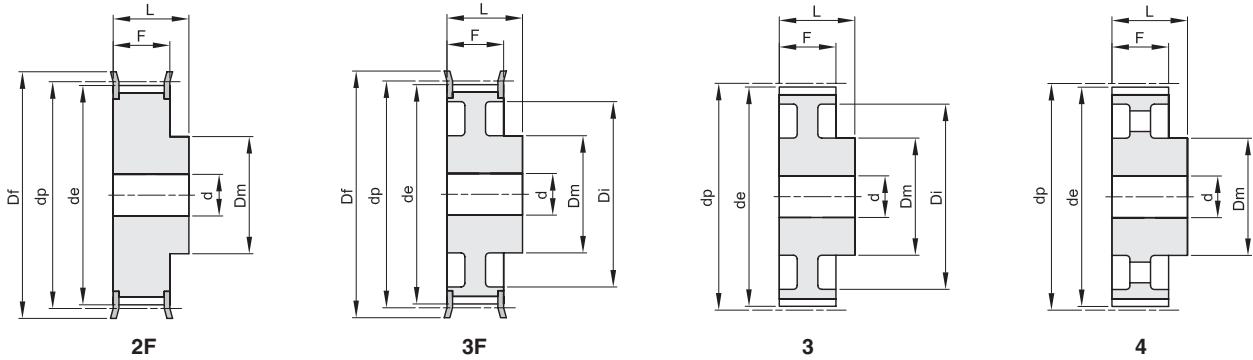

Material: Acero (St)
Material: Fundición (GG)

codigo	tipo	material	dientes	dp	de	Df	Dm	Di	F	L	d	n° guia	Kg.
22 8M 20	2F	St	22	56,02	54,65	60	43		28	38	12	308	0,54
24 8M 20	2F	St	24	61,11	59,74	66	45		28	38	12	310	0,65
26 8M 20	2F	St	26	66,21	64,84	71	48		28	38	12	311	0,80
28 8M 20	2F	St	28	71,30	70,08	75	50		28	38	14	312	0,88
30 8M 20	2F	St	30	76,39	75,13	83	55		28	38	14	314	1,00
32 8M 20	2F	St	32	81,49	80,16	87	60		28	38	14	315	1,20
34 8M 20	2F	St	34	86,58	85,21	91	66		28	38	14	316	1,40
36 8M 20	2F	St	36	91,67	90,30	98	70		28	38	14	319	1,60
38 8M 20	2F	St	38	96,77	95,39	103	75		28	38	14	320	1,70
40 8M 20	2F	St	40	101,86	100,49	106	75		28	38	14	321	1,85
44 8M 20	2F	St	44	112,05	110,67	119	75		28	38	14	325	2,10
48 8M 20	2F	St	48	122,23	120,86	127	75		28	38	14	327	2,50
56 8M 20	3F	St	56	142,60	141,23	148	80	116	28	38	14	333	2,82
64 8M 20	3F	St	64	162,97	161,60	168	80	137	28	38	14	338	3,22
72 8M 20	3F	St	72	183,35	181,97	192	80	158	28	38	14	340	3,74
80 8M 20	3	GG	80	203,72	202,35		90	180	28	38	14		3,78
90 8M 20	3	GG	90	229,18	227,81		90	204	28	38	14		4,57
* 112 8M 20	4	GG	112	285,21	283,83		90	254	28	38	18		
* 144 8M 20	4	GG	144	366,69	365,32		90	336	28	38	20		
* 168 8M 20	4	GG	168	427,81	426,44		100	400	28	38	20		
* 192 8M 20	4	GG	192	488,92	487,55		100	460	28	38	20		

* Construidas bajo pedido - Manufactured on request.



POLEAS DENTADAS PARA CORREAS HTD®

HTD® TIMING BELT PULLEYS

8M

PASO 8 mm

PARA CORREA ANCHO 30 mm

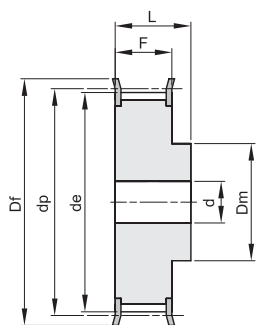

2F

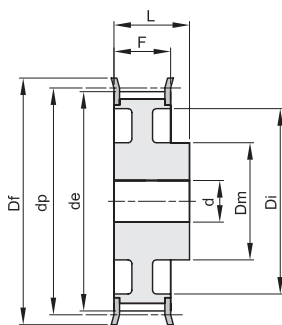

3F

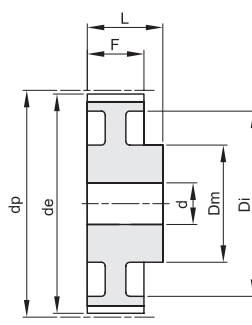

3

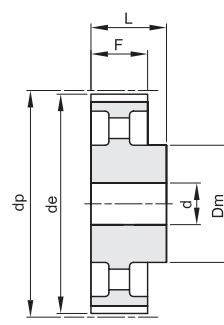

4

Material: Acero (St)

Material: Fundición (GG)

codigo	tipo	material	dientes	dp	de	Df	Dm	Di	F	L	d	n° guia	Kg.
22 8M 30	2F	St	22	56,02	54,65	60	43		38	48	12	308	0,75
24 8M 30	2F	St	24	61,11	59,74	66	45		38	48	12	310	0,90
26 8M 30	2F	St	26	66,21	64,84	71	48		38	48	12	311	1,10
28 8M 30	2F	St	28	71,30	70,08	75	50		38	48	14	312	1,20
30 8M 30	2F	St	30	76,39	75,13	83	55		38	48	14	314	1,32
32 8M 30	2F	St	32	81,49	80,16	87	60		38	48	14	315	1,55
34 8M 30	2F	St	34	86,58	85,21	91	66		38	48	14	316	1,80
36 8M 30	2F	St	36	91,67	90,30	98	70		38	48	14	319	2,10
38 8M 30	2F	St	38	96,77	95,39	103	75		38	48	14	320	2,30
40 8M 30	2F	St	40	101,86	100,49	106	75		38	48	14	321	2,47
44 8M 30	2F	St	44	112,05	110,67	119	75		38	48	14	325	2,95
48 8M 30	2F	St	48	122,23	120,86	127	75		38	48	14	327	3,30
56 8M 30	3F	St	56	142,60	141,23	148	90	116	38	48	14	333	4,02
64 8M 30	3F	St	64	162,97	161,60	168	90	137	38	48	14	338	4,60
72 8M 30	3F	St	72	183,35	181,97	192	95	158	38	48	14	340	5,41
80 8M 30	3	GG	80	203,72	202,35		100	180	38	48	14		5,23
90 8M 30	3	GG	90	229,18	227,81		100	204	38	48	14		6,42
112 8M 30	4	GG	112	285,21	283,83		100	254	38	48	18		8,12
144 8M 30	4	GG	144	366,69	365,32		100	336	38	48	20		10,36
168 8M 30	4	GG	168	427,81	426,44		100	400	38	48	20		12,37
192 8M 30	4	GG	192	488,92	487,55		100	460	38	48	20		14,31



POLEAS DENTADAS PARA CORREAS HTD®

HTD® TIMING BELT PULLEYS

8M

PASO 8 mm

PARA CORREA ANCHO 50 mm

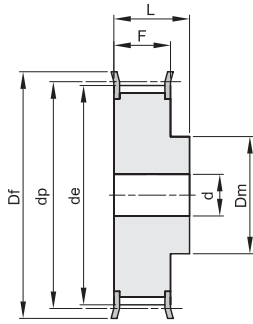

2F

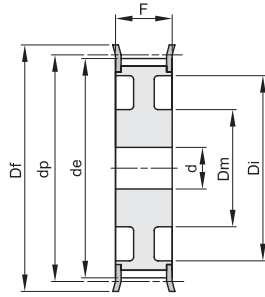

7F

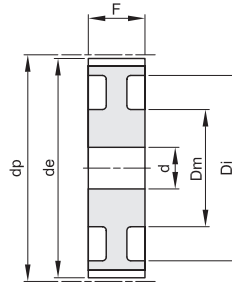

7

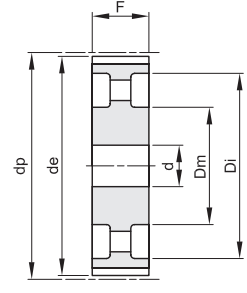

8

Material: Acero (St)
Material: Fundición (GG)

codigo	tipo	material	dientes	dp	de	Df	Dm	Di	F	L	d	n° guia	Kg.
22 8M 50	2F	St	22	56,02	54,65	60	43		60	70	12	308	1,10
24 8M 50	2F	St	24	61,11	59,74	66	45		60	70	12	310	1,30
26 8M 50	2F	St	26	66,21	64,84	71	48		60	70	12	311	1,60
28 8M 50	2F	St	28	71,30	70,08	75	50		60	70	14	312	1,70
30 8M 50	2F	St	30	76,39	75,13	83	55		60	70	14	314	2,00
32 8M 50	2F	St	32	81,49	80,16	87	60		60	70	14	315	2,35
34 8M 50	2F	St	34	86,58	85,21	91	66		60	70	14	316	2,80
36 8M 50	2F	St	36	91,67	90,30	98	70		60	70	14	319	3,10
38 8M 50	2F	St	38	96,77	95,39	103	75		60	70	14	320	3,30
40 8M 50	2F	St	40	101,86	100,49	106	75		60	70	14	321	3,60
44 8M 50	2F	St	44	112,05	110,67	119	75		60	70	14	325	4,40
48 8M 50	2F	St	48	122,23	120,86	127	75		60	70	14	327	5,00
56 8M 50	7F	St	56	142,60	141,23	148	90	116	60	60	18	333	5,68
64 8M 50	7F	St	64	162,97	161,60	168	100	137	60	60	18	338	6,93
72 8M 50	7F	St	72	183,35	181,97	192	100	158	60	60	18	340	7,95
80 8M 50	7	GG	80	203,72	202,35		110	180	60	60	18		7,96
90 8M 50	7	GG	90	229,18	227,81		110	204	60	60	18		9,20
112 8M 50	8	GG	112	285,21	283,83		110	254	60	60	18		12,16
144 8M 50	8	GG	144	366,69	365,32		110	336	60	60	20		15,68
168 8M 50	8	GG	168	427,81	426,44		120	400	60	60	20		18,99
192 8M 50	8	GG	192	488,92	487,55		130	460	60	60	20		24,09



POLEAS DENTADAS PARA CORREAS HTD®

HTD® TIMING BELT PULLEYS

8M

PASO 8 mm

PARA CORREA ANCHO 85 mm

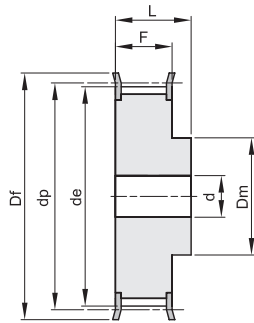

2F

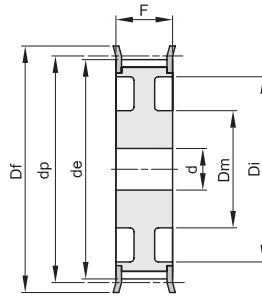

7F

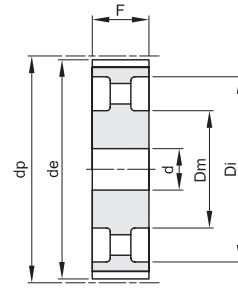

8

Material: Acero (St)

Material: Fundición (GG)

codigo	tipo	material	dientes	dp	de	Df	Dm	Di	F	L	d	n° guía	Kg.
22 8M 85	2F	St	22	56,02	54,65	60	43		95	105	12	308	1,60
24 8M 85	2F	St	24	61,11	59,74	66	45		95	105	12	310	1,95
26 8M 85	2F	St	26	66,21	64,84	71	48		95	105	12	311	2,30
28 8M 85	2F	St	28	71,30	70,08	75	50		95	105	14	312	2,60
30 8M 85	2F	St	30	76,39	75,13	83	55		95	105	14	314	3,10
32 8M 85	2F	St	32	81,49	80,16	87	60		95	105	14	315	3,70
34 8M 85	2F	St	34	86,58	85,21	91	66		95	105	14	316	4,00
36 8M 85	2F	St	36	91,67	90,30	98	70		95	105	14	319	4,70
38 8M 85	2F	St	38	96,77	95,39	103	75		95	105	14	320	5,10
40 8M 85	2F	St	40	101,86	100,49	106	75		95	105	14	321	5,40
44 8M 85	2F	St	44	112,05	110,67	119	75		95	105	14	325	6,70
48 8M 85	2F	St	48	122,23	120,86	127	75		95	105	14	327	7,20
56 8M 85	2F	St	56	142,60	141,23	148	90		95	105	18	333	11,48
64 8M 85	7F	St	64	162,97	161,60	168	100	137	95	95	18	338	11,02
72 8M 85	7F	St	72	183,35	181,97	192	100	158	95	95	18	340	13,45
80 8M 85	8	GG	80	203,72	202,35		110	180	95	95	20		12,36
90 8M 85	8	GG	90	229,18	227,81		110	204	95	95	20		14,38
112 8M 85	8	GG	112	285,21	283,83		110	254	95	95	24		18,66
144 8M 85	8	GG	144	366,69	365,32		110	341	95	95	24		23,00
* 168 8M 85	8	GG	168	427,81	426,44		120	400	95	95	24		
* 192 8M 85	8	GG	192	488,92	487,55		130	460	95	95	24		

* Construidas bajo pedido - Manufactured on request.



POLEAS DENTADAS PARA CORREAS HTD®

HTD® TIMING BELT PULLEYS

14M

PASO 14 mm
PARA CORREA ANCHO 40 mm

Material: Acero (St)
Material: Fundición (GG)

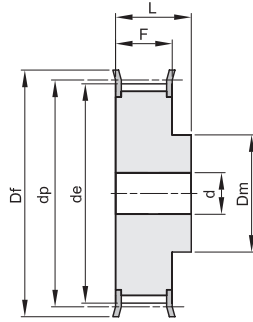

2F

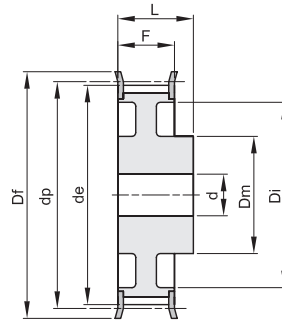

3F

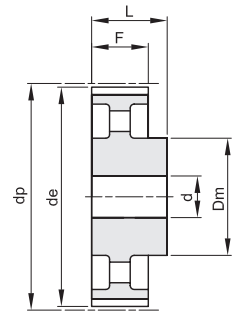

4

codigo	tipo	material	dientes	dp	de	Df	Dm	Di	F	L	d	n° guia	Kg.
28 14M 40	2F	St	28	124,78	122,12	127	100		54	69	24	400	4,80
30 14M 40	2F	St	30	133,69	130,99	138	100		54	69	24	401	5,60
32 14M 40	2F	St	32	142,60	139,88	154	100		54	69	24	403	6,20
34 14M 40	2F	St	34	151,52	148,79	160	100		54	69	24	404	6,90
36 14M 40	2F	St	36	160,43	157,68	168	100		54	69	24	405	7,70
38 14M 40	2F	St	38	169,34	166,60	183	120		54	69	24	406	8,90
40 14M 40	2F	St	40	178,25	175,49	188	120		54	69	24	407	9,80
44 14M 40	2F	St	44	196,08	193,28	211	120		54	69	24	411	12,00
48 14M 40	3F	GG	48	213,90	211,11	226	135	170	54	69	24	412	11,98
56 14M 40	3F	GG	56	249,55	246,76	256	135	207	54	69	28	416	14,01
64 14M 40	3F	GG	64	285,21	282,41	296	135	240	54	69	28	418	16,65
72 14M 40	4	GG	72	320,86	318,06		135	278	54	69	28		15,52
80 14M 40	4	GG	80	356,51	353,71		135	314	54	69	28		17,23
90 14M 40	4	GG	90	401,07	398,28		135	358	54	69	28		19,40
112 14M 40	4	GG	112	499,11	496,32		135	456	54	69	28		24,14
* 144 14M 40	4	GG	144	641,71	638,92		135	600	54	69	28		
* 168 14M 40	4	GG	168	748,66	745,87		135	706	54	69	28		
* 192 14M 40	4	GG	192	855,62	852,82		135	813	54	69	28		

* Construidas bajo pedido - Manufactured on request.



POLEAS DENTADAS PARA CORREAS HTD®

HTD® TIMING BELT PULLEYS

14M

PASO 14 mm

PARA CORREA ANCHO 55 mm

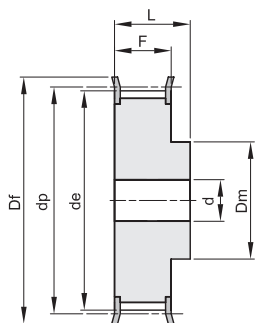

2F

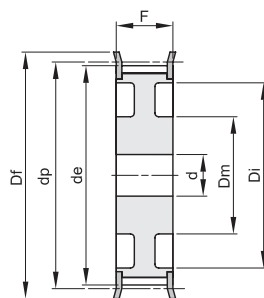

7F

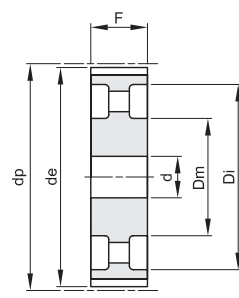

8

Material: Acero (St)
Material: Fundición (GG)

codigo	tipo	material	dientes	dp	de	Df	Dm	Di	F	L	d	n° guia	Kg.
28 14M 55	2F	St	28	124,78	122,12	127	100		70	85	24	400	5,70
30 14M 55	2F	St	30	133,69	130,99	138	100		70	85	24	401	7,10
32 14M 55	2F	St	32	142,60	139,88	154	100		70	85	24	403	7,90
34 14M 55	2F	St	34	151,52	148,79	160	100		70	85	24	404	9,33
36 14M 55	2F	St	36	160,43	157,68	168	100		70	85	24	405	10,49
38 14M 55	2F	St	38	169,34	166,60	183	120		70	85	24	406	12,11
40 14M 55	2F	St	40	178,25	175,49	188	120		70	85	24	407	13,30
44 14M 55	2F	St	44	196,08	193,28	211	120		70	85	24	411	16,12
48 14M 55	7F	GG	48	213,90	211,11	226	135	170	70	70	24	412	13,50
56 14M 55	7F	GG	56	249,55	246,76	256	135	207	70	70	28	416	15,78
64 14M 55	7F	GG	64	285,21	282,41	296	135	240	70	70	28	418	19,04
72 14M 55	8	GG	72	320,86	318,06		135	278	70	70	28		18,41
80 14M 55	8	GG	80	356,51	353,71		135	314	70	70	28		20,27
90 14M 55	8	GG	90	401,07	398,28		135	358	70	70	28		22,98
112 14M 55	8	GG	112	499,11	496,32		135	456	70	70	28		29,29
144 14M 55	8	GG	144	641,71	638,92		135	600	70	70	28		36,00
168 14M 55	8	GG	168	748,66	745,87		135	706	70	70	28		40,00
192 14M 55	8	GG	192	855,62	852,82		135	813	70	70	28		47,50



POLEAS DENTADAS PARA CORREAS HTD®

HTD® TIMING BELT PULLEYS

14M

PASO 14 mm
PARA CORREA ANCHO 85 mm

Material: Acero (St)
Material: Fundición (GG)

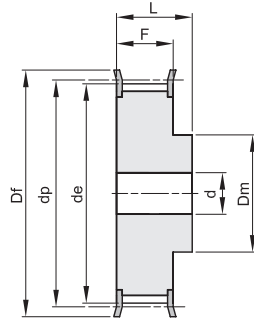

2F

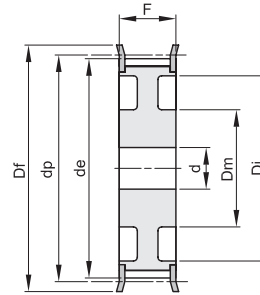

7F

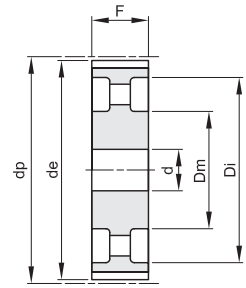

8

codigo	tipo	material	dientes	dp	de	Df	Dm	Di	F	L	d	n° guia	Kg.
28 14M 85	2F	St	28	124,78	122,12	127	100		102	117	24	400	8,77
30 14M 85	2F	St	30	133,69	130,99	138	100		102	117	24	401	10,13
32 14M 85	2F	St	32	142,60	139,88	154	100		102	117	24	403	11,65
34 14M 85	2F	St	34	151,52	148,79	160	100		102	117	24	404	13,15
36 14M 85	2F	St	36	160,43	157,68	168	100		102	117	32	405	14,48
38 14M 85	2F	St	38	169,34	166,60	183	120		102	117	32	406	16,62
40 14M 85	2F	St	40	178,25	175,49	188	135		102	117	32	407	18,84
44 14M 85	2F	St	44	196,08	193,28	211	135		102	117	32	411	22,86
48 14M 85	2F	St	48	213,90	211,11	226	150		102	117	32	412	27,58
56 14M 85	7F	GG	56	249,55	246,76	256	150	207	102	102	32	416	24,19
64 14M 85	7F	GG	64	285,21	282,41	296	150	240	102	102	32	418	28,57
72 14M 85	8	GG	72	320,86	318,06		150	278	102	102	32		28,26
80 14M 85	8	GG	80	356,51	353,71		150	314	102	102	32		31,00
90 14M 85	8	GG	90	401,07	398,28		150	358	102	102	32		35,00
112 14M 85	8	GG	112	499,11	496,32		150	456	102	102	32		43,50
144 14M 85	8	GG	144	641,71	638,92		150	600	102	102	32		50,00
168 14M 85	8	GG	168	748,66	745,87		150	706	102	102	32		63,00
192 14M 85	8	GG	192	855,62	852,82		165	813	102	102	32		76,00



POLEAS DENTADAS PARA CORREAS HTD®

HTD® TIMING BELT PULLEYS

14M

PASO 14 mm

PARA CORREA ANCHO 115 mm

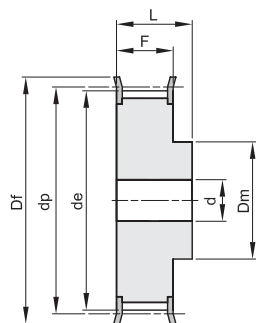

2F

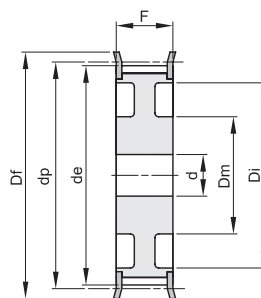

7F

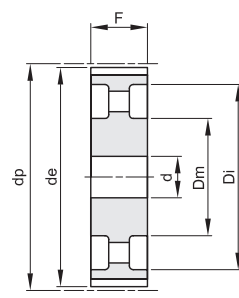

8

Material: Acero (St)
Material: Fundición (GG)

codigo	tipo	material	dientes	dp	de	Df	Dm	Di	F	L	d	n° guia	Kg.
28 14M 115	2F	St	28	124,78	122,12	127	100		133	148	32	400	10,75
30 14M 115	2F	St	30	133,69	130,99	138	100		133	148	32	401	12,52
32 14M 115	2F	St	32	142,60	139,88	154	100		133	148	32	403	14,48
34 14M 115	2F	St	34	151,52	148,79	160	100		133	148	32	404	16,45
36 14M 115	2F	St	36	160,43	157,68	168	120		133	148	32	405	18,99
38 14M 115	2F	St	38	169,34	166,60	183	120		133	148	32	406	21,31
40 14M 115	2F	St	40	178,25	175,49	188	135		133	148	32	407	24,04
44 14M 115	2F	St	44	196,08	193,28	211	140		133	148	32	411	29,41
48 14M 115	2F	St	48	213,90	211,11	226	150		133	148	32	412	35,00
56 14M 115	2F	St	56	249,55	246,76	256	150		133	148	32	416	48,00
64 14M 115	7F	GG	64	285,21	282,41	296	150	240	133	133	32	418	36,00
72 14M 115	8	GG	72	320,86	318,06		150	278	133	133	32		36,00
80 14M 115	8	GG	80	356,51	353,71		150	314	133	133	32		40,00
90 14M 115	8	GG	90	401,07	398,28		150	358	133	133	32		45,00
112 14M 115	8	GG	112	499,11	496,32		150	456	133	133	32		55,50
144 14M 115	8	GG	144	641,71	638,92		165	600	133	133	32		71,00
168 14M 115	8	GG	168	748,66	745,87		165	706	133	133	32		83,00
192 14M 115	8	GG	192	855,62	852,82		165	813	133	133	32		96,00



POLEAS DENTADAS PARA CORREAS HTD®

HTD® TIMING BELT PULLEYS

14M

PASO 14 mm

PARA CORREA ANCHO 170 mm

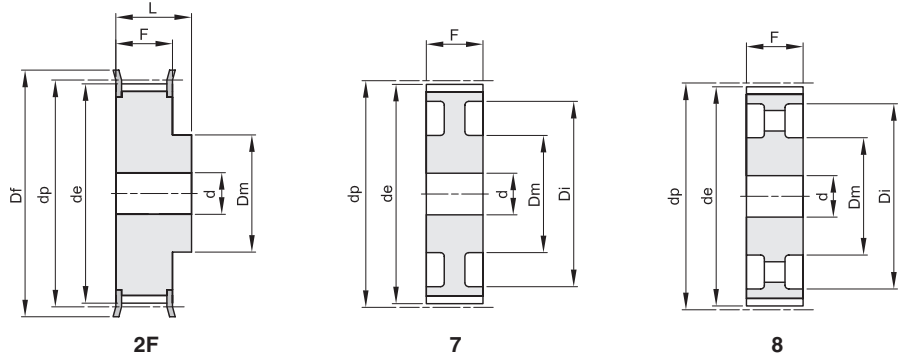

Material: Acero (St)
Material: Fundición (GG)

codigo	tipo	material	dientes	dp	de	Df	Dm	Di	F	L	d	n° guia	Kg.
28 14M 170	2F	St	28	124,78	122,12	127	100		187	202	32	400	14,79
30 14M 170	2F	St	30	133,69	130,99	138	100		187	202	32	401	17,24
32 14M 170	2F	St	32	142,60	139,88	154	100		187	202	32	403	19,92
34 14M 170	2F	St	34	151,52	148,79	160	100		187	202	32	404	22,72
36 14M 170	2F	St	36	160,43	157,68	168	120		187	202	32	405	26,07
38 14M 170	2F	St	38	169,34	166,60	183	135		187	202	32	406	29,71
40 14M 170	2F	St	40	178,25	175,49	188	140		187	202	32	407	33,50
*44 14M 170	2F	St	44	196,08	193,28	211	160		187	202	32	411	
*48 14M 170	2F	St	48	213,90	211,11	226	160		187	202	32	412	
*56 14M 170	2F	St	56	249,55	246,76	256	160		187	202	32	416	
*64 14M 170	2F	St	64	285,21	282,41	296	180		187	202	32	418	
*72 14M 170	7	GG	72	320,86	318,06		180	278	187	187	32		
80 14M 170	7	GG	80	356,51	353,71		180	314	187	187	32		71,00
90 14M 170	8	GG	90	401,07	398,28		180	358	187	187	38		73,00
112 14M 170	8	GG	112	499,11	496,32		200	456	187	187	38		95,00
144 14M 170	8	GG	144	641,71	638,92		220	600	187	187	38		114,00
168 14M 170	8	GG	168	748,66	745,87		220	706	187	187	38		142,00
*192 14M 170	8	GG	192	855,62	852,82		220	813	187	187	38		

* Construidas bajo pedido - Manufactured on request.