



POLEAS DENTADAS PASO METRICO SERIE "T" - DIN 7721-2

METRIC PULLEYS "T" - DIN 7721-2

T 2,5

PASO 2,5 mm

PARA CORREA DE ANCHO 6 mm

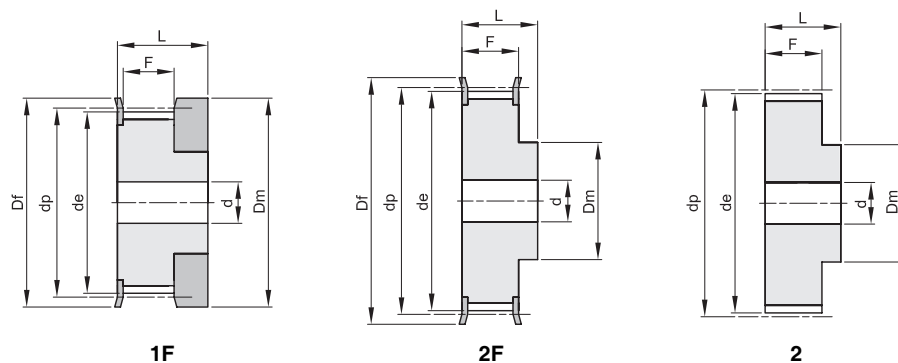

Material: Aluminio UNI 9006 - T6 (Al)

codigo	tipo	material	dientes	de	Df	Dm	F	L	d	n° guia	Kg.
16 T 2,5 12	1F	Al	12	9,00	13	12	9	16		100	0,01
16 T 2,5 14	1F	Al	14	10,60	15	14	9	16		101	0,01
16 T 2,5 15	1F	Al	15	11,40	15	15	9	16		101	0,01
16 T 2,5 16	1F	Al	16	12,20	16	16	9	16		102	0,01
16 T 2,5 18	2F	Al	18	13,80	18	10	10	16	3	104	0,01
16 T 2,5 19	2F	Al	19	14,60	18	10	10	16	3	104	0,01
16 T 2,5 20	2F	Al	20	15,40	19,5	11	10	16	3	105	0,01
16 T 2,5 22	2F	Al	22	17,00	23	11	10	16	3	106	0,01
16 T 2,5 24	2F	Al	24	18,55	23	12	10	16	3	107	0,01
16 T 2,5 25	2F	Al	25	19,35	23	13	10	16	3	107	0,01
16 T 2,5 26	2F	Al	26	20,15	25	14	10	16	4	108	0,01
16 T 2,5 28	2F	Al	28	21,75	25	14	10	16	4	108	0,02
16 T 2,5 30	2F	Al	30	23,35	28	16	10	16	6	109	0,02
16 T 2,5 32	2F	Al	32	24,95	32	16	10	16	6	110	0,02
16 T 2,5 36	2F	Al	36	28,10	36	20	10	16	6	111	0,03
16 T 2,5 40	2F	Al	40	31,30	38	22	10	16	6	112	0,03
16 T 2,5 44	2	Al	44	34,50		24	10	16	6		0,04
16 T 2,5 48	2	Al	48	37,70		26	10	16	6		0,05
16 T 2,5 60	2	Al	60	47,25		34	10	16	8		0,07



POLEAS DENTADAS PASO METRICO SERIE "T" - DIN 7721-2

METRIC PULLEYS "T" - DIN 7721-2

T 5

PASO 5 mm

PARA CORREA DE ANCHO 10 mm

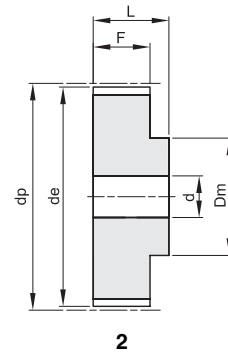
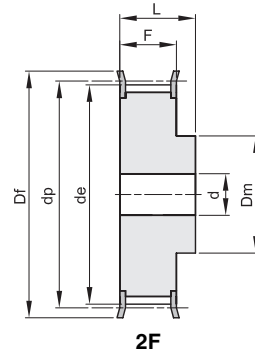

Material : Aluminio UNI 9006 - T6 (Al)

codigo	tipo	material	dientes	de	Df	Dm	F	L	d	n° guia	Kg.
21 T 5 10	2F	Al	10	15,05	19,5	8	15	21		200	0,01
21 T 5 12	2F	Al	12	18,25	23	10	15	21		201	0,01
21 T 5 14	2F	Al	14	21,45	25	13	15	21		203	0,02
21 T 5 15	2F	Al	15	23,05	28	16	15	21		204	0,02
21 T 5 16	2F	Al	16	24,60	32	18	15	21		205	0,03
21 T 5 18	2F	Al	18	27,80	32	20	15	21		205	0,03
21 T 5 19	2F	Al	19	29,40	36	22	15	21		206	0,04
21 T 5 20	2F	Al	20	31,00	36	23	15	21		206	0,04
21 T 5 22	2F	Al	22	34,25	38	24	15	21		207	0,05
21 T 5 24	2F	Al	24	37,40	42	26	15	21		208	0,06
21 T 5 25	2F	Al	25	38,95	44	26	15	21		209	0,06
21 T 5 26	2F	Al	26	40,60	44	26	15	21		209	0,06
21 T 5 27	2F	Al	27	42,20	48	30	15	21	8	210	0,07
21 T 5 28	2F	Al	28	43,75	48	32	15	21	8	210	0,07
21 T 5 30	2F	Al	30	46,95	51	34	15	21	8	211	0,07
21 T 5 32	2F	Al	32	50,10	54	38	15	21	8	212	0,09
21 T 5 36	2F	Al	36	56,45	63	38	15	21	8	215	0,11
21 T 5 40	2F	Al	40	62,85	66	40	15	21	8	216	0,14
21 T 5 42	2F	Al	42	66,00	71	40	15	21	8	217	0,18
21 T 5 44	2	Al	44	69,20		45	15	21	8		0,18
21 T 5 48	2	Al	48	75,55		50	15	21	8		0,20
21 T 5 60	2	Al	60	94,65		65	15	21	8		0,31



POLEAS DENTADAS PASO METRICO SERIE "T" - DIN 7721-2

METRIC PULLEYS "T" - DIN 7721-2

T 5

PASO 5 mm

PARA CORREA DE ANCHO 16 mm

Material: Aluminio UNI 9006 - T6 (Al)

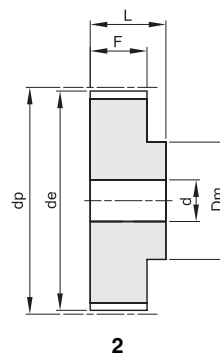
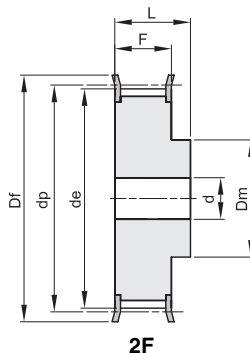

codigo	tipo	material	dientes	de	Df	Dm	F	L	d	n° guia	Kg.
27 T 5 10	2F	Al	10	15,05	19,5	8	21	27		200	0,02
27 T 5 12	2F	Al	12	18,25	23	10	21	27		201	0,02
27 T 5 14	2F	Al	14	21,45	25	13	21	27		203	0,03
27 T 5 15	2F	Al	15	23,05	28	16	21	27		204	0,03
27 T 5 16	2F	Al	16	24,60	32	18	21	27		205	0,04
27 T 5 18	2F	Al	18	27,80	32	20	21	27		205	0,04
27 T 5 19	2F	Al	19	29,40	36	22	21	27		206	0,05
27 T 5 20	2F	Al	20	31,00	36	23	21	27		206	0,06
27 T 5 22	2F	Al	22	34,25	38	24	21	27		207	0,06
27 T 5 24	2F	Al	24	37,40	42	26	21	27		208	0,08
27 T 5 25	2F	Al	25	38,95	44	26	21	27		209	0,08
27 T 5 26	2F	Al	26	40,60	44	26	21	27		209	0,09
27 T 5 27	2F	Al	27	42,20	48	30	21	27	8	210	0,09
27 T 5 28	2F	Al	28	43,75	48	32	21	27	8	210	0,09
27 T 5 30	2F	Al	30	46,95	51	34	21	27	8	211	0,10
27 T 5 32	2F	Al	32	50,10	54	38	21	27	8	212	0,12
27 T 5 36	2F	Al	36	56,45	63	38	21	27	8	215	0,16
27 T 5 40	2F	Al	40	62,85	66	40	21	27	8	216	0,19
27 T 5 42	2F	Al	42	66,00	71	40	21	27	8	217	0,20
27 T 5 44	2	Al	44	69,20		45	21	27	8		0,23
27 T 5 48	2	Al	48	75,55		50	21	27	8		0,28
27 T 5 60	2	Al	60	94,65		65	21	27	8		0,43



POLEAS DENTADAS PASO METRICO SERIE "T" - DIN 7721-2

METRIC PULLEYS "T" - DIN 7721-2

T 5

PASO 5 mm

PARA CORREA DE ANCHO 25 mm

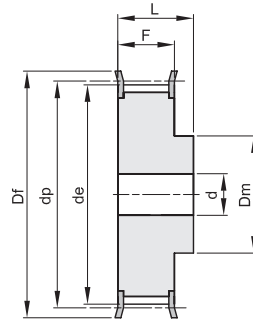

2F

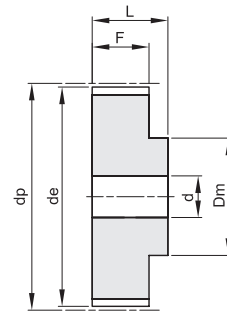

2

Material: Aluminio UNI 9006 - T6 (Al)

codigo	tipo	material	dientes	de	Df	Dm	F	L	d	n° guia	Kg.
36 T 5 10	2F	Al	10	15,05	19,5	8	30	36		200	0,02
36 T 5 12	2F	Al	12	18,25	23	10	30	36		201	0,03
36 T 5 14	2F	Al	14	21,45	25	13	30	36		203	0,04
36 T 5 15	2F	Al	15	23,05	28	16	30	36		204	0,04
36 T 5 16	2F	Al	16	24,60	32	18	30	36		205	0,05
36 T 5 18	2F	Al	18	27,80	32	20	30	36		205	0,06
36 T 5 19	2F	Al	19	29,40	36	22	30	36		206	0,07
36 T 5 20	2F	Al	20	31,00	36	23	30	36		206	0,08
36 T 5 22	2F	Al	22	34,25	38	24	30	36		207	0,08
36 T 5 24	2F	Al	24	37,40	42	26	30	36		208	0,11
36 T 5 25	2F	Al	25	38,95	44	26	30	36		209	0,12
36 T 5 26	2F	Al	26	40,60	44	26	30	36		209	0,12
36 T 5 27	2F	Al	27	42,20	48	30	30	36	8	210	0,13
36 T 5 28	2F	Al	28	43,75	48	32	30	36	8	210	0,14
36 T 5 30	2F	Al	30	46,95	51	34	30	36	8	211	0,15
36 T 5 32	2F	Al	32	50,10	54	38	30	36	8	212	0,18
36 T 5 36	2F	Al	36	56,45	63	38	30	36	8	215	0,23
36 T 5 40	2F	Al	40	62,85	66	40	30	36	8	216	0,28
36 T 5 42	2F	Al	42	66,00	71	40	30	36	8	217	0,29
36 T 5 44	2	Al	44	69,20		45	30	36	8		0,31
36 T 5 48	2	Al	48	75,55		50	30	36	8		0,40
36 T 5 60	2	Al	60	94,65		65	30	36	8		0,61



POLEAS DENTADAS PASO METRICO SERIE "T" - DIN 7721-2

METRIC PULLEYS "T" - DIN 7721-2

T 10

PASO 10 mm

PARA CORREA DE ANCHO 16 mm

Material: Aluminio UNI 9006 - T6 (Al)

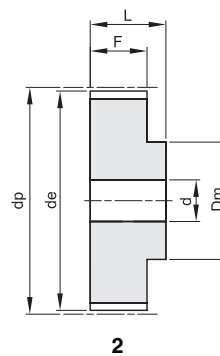
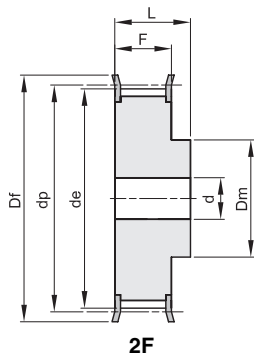

codigo	tipo	material	dientes	de	Df	Dm	F	L	d	n° guia	Kg.
31 T 10 12	2F	Al	12	36,35	42	28	21	31	6	208	0,08
31 T 10 14	2F	Al	14	42,70	48	32	21	31	8	210	0,10
31 T 10 15	2F	Al	15	45,90	51	32	21	31	8	211	0,12
31 T 10 16	2F	Al	16	49,10	54	35	21	31	8	212	0,13
31 T 10 18	2F	Al	18	55,45	60	40	21	31	8	214	0,17
31 T 10 19	2F	Al	19	58,65	66	44	21	31	8	216	0,18
31 T 10 20	2F	Al	20	61,80	66	46	21	31	8	216	0,21
31 T 10 22	2F	Al	22	68,20	75	52	21	31	8	218	0,25
31 T 10 24	2F	Al	24	74,55	83	58	21	31	8	219	0,29
31 T 10 25	2F	Al	25	77,75	83	60	21	31	8	219	0,31
31 T 10 26	2F	Al	26	80,90	87	60	21	31	8	220	0,36
31 T 10 27	2F	Al	27	84,10	91	60	21	31	8	221	0,37
31 T 10 28	2F	Al	28	87,25	93	60	21	31	8	222	0,40
31 T 10 30	2F	Al	30	93,65	97	60	21	31	8	223	0,44
31 T 10 32	2F	Al	32	100,00	106	65	21	31	10	224	0,49
31 T 10 36	2F	Al	36	112,75	119	70	21	31	10	225	0,62
31 T 10 40	2F	Al	40	125,45	131	80	21	31	10	226	0,77
31 T 10 44	2	Al	44	138,20		88	21	31	10		1,00
31 T 10 48	2	Al	48	150,95		95	21	31	16		1,10
31 T 10 60	2	Al	60	189,15		110	21	31	16		1,70



POLEAS DENTADAS PASO METRICO SERIE "T" - DIN 7721-2

METRIC PULLEYS "T" - DIN 7721-2

T 10
PASO 10 mm
 PARA CORREA DE ANCHO 25 mm

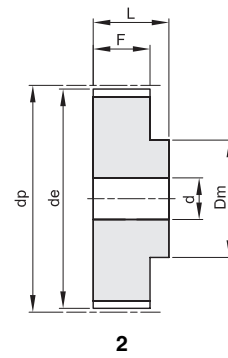
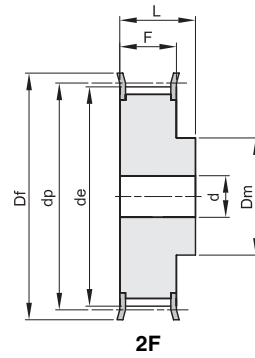

Material: Aluminio UNI 9006 - T6 (Al)

codigo	tipo	material	dientes	de	Df	Dm	F	L	d	n° guia	Kg.
40 T 10 12	2F	Al	12	36,35	42	28	30	40	6	208	0,10
40 T 10 14	2F	Al	14	42,70	48	32	30	40	8	210	0,13
40 T 10 15	2F	Al	15	45,90	51	32	30	40	8	211	0,15
40 T 10 16	2F	Al	16	49,10	54	35	30	40	8	212	0,18
40 T 10 18	2F	Al	18	55,45	60	40	30	40	8	214	0,22
40 T 10 19	2F	Al	19	58,65	66	44	30	40	8	216	0,25
40 T 10 20	2F	Al	20	61,80	66	46	30	40	8	216	0,28
40 T 10 22	2F	Al	22	68,20	75	52	30	40	8	218	0,34
40 T 10 24	2F	Al	24	74,55	83	58	30	40	8	219	0,39
40 T 10 25	2F	Al	25	77,75	83	60	30	40	8	219	0,42
40 T 10 26	2F	Al	26	80,90	87	60	30	40	8	220	0,48
40 T 10 27	2F	Al	27	84,10	91	60	30	40	8	221	0,54
40 T 10 28	2F	Al	28	87,25	93	60	30	40	8	222	0,55
40 T 10 30	2F	Al	30	93,65	97	60	30	40	8	223	0,64
40 T 10 32	2F	Al	32	100,00	106	65	30	40	10	224	0,69
40 T 10 36	2F	Al	36	112,75	119	70	30	40	10	225	0,87
40 T 10 40	2F	Al	40	125,45	131	80	30	40	10	226	1,07
40 T 10 44	2	Al	44	138,20		88	30	40	10		1,35
40 T 10 48	2	Al	48	150,95		95	30	40	16		1,52
40 T 10 60	2	Al	60	189,15		110	30	40	16		2,34



POLEAS DENTADAS PASO METRICO SERIE "T" - DIN 7721-2

METRIC PULLEYS "T" - DIN 7721-2

T 10

PASO 10 mm

PARA CORREA DE ANCHO 32 mm

Material: Aluminio UNI 9006 - T6 (Al)

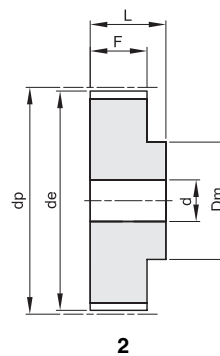
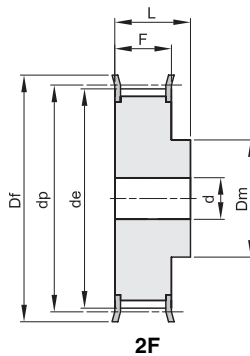

codigo	tipo	material	dientes	de	Df	Dm	F	L	d	n° guia	Kg.
47 T 10 18	2F	Al	18	55,45	60	40	37	47	10	214	0,25
47 T 10 19	2F	Al	19	58,65	66	44	37	47	10	216	0,29
47 T 10 20	2F	Al	20	61,80	66	46	37	47	12	216	0,32
47 T 10 22	2F	Al	22	68,20	75	52	37	47	12	218	0,39
47 T 10 24	2F	Al	24	74,55	83	58	37	47	12	219	0,47
47 T 10 25	2F	Al	25	77,75	83	60	37	47	12	219	0,53
47 T 10 26	2F	Al	26	80,90	87	60	37	47	12	220	0,56
47 T 10 27	2F	Al	27	84,10	91	60	37	47	12	221	0,60
47 T 10 28	2F	Al	28	87,25	93	60	37	47	12	222	0,64
47 T 10 30	2F	Al	30	93,65	97	60	37	47	12	223	0,74
47 T 10 32	2F	Al	32	100,00	106	65	37	47	12	224	0,84
47 T 10 36	2F	Al	36	112,75	119	70	37	47	16	225	1,06
47 T 10 40	2F	Al	40	125,45	131	80	37	47	16	226	1,32
47 T 10 44	2	Al	44	138,20		88	37	47	16		1,61
47 T 10 48	2	Al	48	150,95		95	37	47	16		1,93
47 T 10 60	2	Al	60	189,10		110	37	47	16		3,00



POLEAS DENTADAS PASO METRICO SERIE "T" - DIN 7721-2

METRIC PULLEYS "T" - DIN 7721-2

T 10
PASO 10 mm
 PARA CORREA DE ANCHO 50 mm

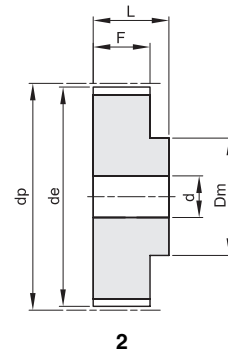
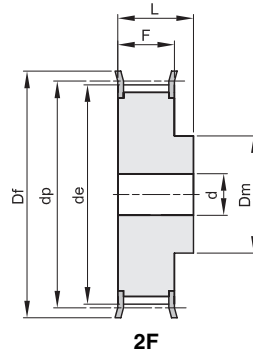

Material: Aluminio UNI 9006 - T6 (Al)

codigo	tipo	material	dientes	de	Df	Dm	F	L	d	n° guia	Kg.
66 T 10 18	2F	Al	18	55,45	60	40	56	66	10	214	0,42
66 T 10 19	2F	Al	19	58,65	66	44	56	66	10	216	0,47
66 T 10 20	2F	Al	20	61,80	66	46	56	66	12	216	0,52
66 T 10 22	2F	Al	22	68,20	75	52	56	66	12	218	0,57
66 T 10 24	2F	Al	24	74,55	83	58	56	66	12	219	0,74
66 T 10 25	2F	Al	25	77,75	83	60	56	66	12	219	0,77
66 T 10 26	2F	Al	26	80,90	87	60	56	66	12	220	0,82
66 T 10 27	2F	Al	27	84,10	91	60	56	66	12	221	0,95
66 T 10 28	2F	Al	28	87,25	93	60	56	66	12	222	0,96
66 T 10 30	2F	Al	30	93,65	97	60	56	66	12	223	1,17
66 T 10 32	2F	Al	32	100,00	106	65	56	66	12	224	1,30
66 T 10 36	2F	Al	36	112,75	119	70	56	66	16	225	1,64
66 T 10 40	2F	Al	40	125,45	131	80	56	66	16	226	2,00
66 T 10 44	2	Al	44	138,20		88	56	66	16		2,36
66 T 10 48	2	Al	48	150,95		95	56	66	16		2,83
66 T 10 60	2	Al	60	189,10		110	56	66	16		4,37