

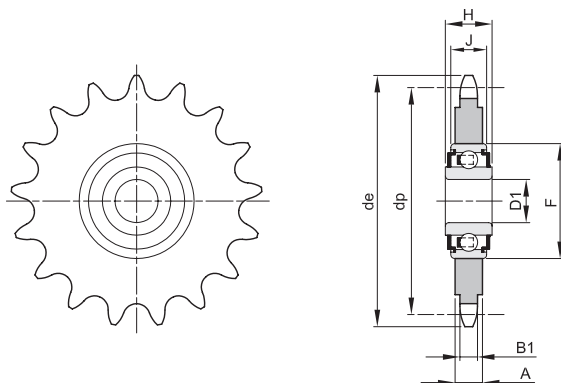

## PIÑONES TENSORES CON RODAMIENTO CHAIN-STRETCHER SPROCKETS WITH BALL BEARING



Z	paso	ISO	De	Dp	B1	A	D1	F	H	J	Kg.
23	8 x 1/8"	05B-1	62,2	58,75	2,8	7,0	16 <sup>+0,26</sup> / <sub>+0,13</sub>	40	18,3	12	0,13
21	3/8" x 7/32"	06B-1	67,6	63,91	5,3	5,3	16 <sup>+0,26</sup> / <sub>+0,13</sub>	40	18,3	12	0,15
22	3/8" x 7/32"	06B-1	70,6	66,93	5,3	5,3	16 <sup>+0,26</sup> / <sub>+0,13</sub>	40	18,3	12	0,16
18	1/2" x 1/8"	081-1	79,4	73,14	3,0	7,0	16 <sup>+0,26</sup> / <sub>+0,13</sub>	40	18,3	12	0,18
15	1/2" x 3/16"	083-1	67,4	61,09	4,5	7,0	16 <sup>+0,26</sup> / <sub>+0,13</sub>	40	18,3	12	0,16
16	1/2" x 3/16"	083-1	71,4	65,10	4,5	7,0	16 <sup>+0,26</sup> / <sub>+0,13</sub>	40	18,3	12	0,17
18	1/2" x 3/16"	083-1	79,4	73,14	4,5	7,0	16 <sup>+0,26</sup> / <sub>+0,13</sub>	40	18,3	12	0,20
14	1/2" x 5/16"	08B-1	61,9	57,07	7,2	7,2	16 <sup>+0,26</sup> / <sub>+0,13</sub>	40	18,3	12	0,13
16	1/2" x 5/16"	08B-1	69,9	65,10	7,2	7,2	16 <sup>+0,26</sup> / <sub>+0,13</sub>	40	18,3	12	0,17
18	1/2" x 5/16"	08B-1	78,0	73,14	7,2	7,2	16 <sup>+0,26</sup> / <sub>+0,13</sub>	40	18,3	12	0,22
14	5/8" x 3/8"	10B-1	78,2	71,34	9,1	9,1	16 <sup>+0,26</sup> / <sub>+0,13</sub>	40	18,3	12	0,23
15	5/8" x 3/8"	10B-1	83,2	76,36	9,1	9,1	16 <sup>+0,26</sup> / <sub>+0,13</sub>	40	18,3	12	0,27
17	5/8" x 3/8"	10B-1	93,3	86,39	9,1	9,1	16 <sup>+0,26</sup> / <sub>+0,13</sub>	40	18,3	12	0,36
13	3/4" x 7/16"	12B-1	87,8	79,59	11,1	11,1	16 <sup>+0,26</sup> / <sub>+0,13</sub>	40	18,3	12	0,34
15	3/4" x 7/16"	12B-1	99,8	91,63	11,1	11,1	16 <sup>+0,26</sup> / <sub>+0,13</sub>	40	18,3	12	0,47
12	1" x 17,02	16B-1	109,7	98,14	16,2	16,2	20 <sup>+0,10</sup> / <sub>-0</sub>	47	17,7	14	0,72
13	1"1/4 x 3/4"	20B-1	147,7	132,67	18,5	18,5	25 <sup>+0,10</sup> / <sub>-0</sub>	52	21	15	1,64



## ELEMENTOS DE FIJACION PARA PIÑONES TENSACADENA LOCKING PARTS FOR CHAIN STRETCHER SPROCKETS

Gli Elementi di fissaggio per tendicatena sono stati realizzati per facilitare e velocizzare il montaggio del Pignone Tendicatena.

Il set degli elementi è composto da: una vite con testa cava esagonale; una bussola per la guida del foro; un dado esagonale autobloccante.

*The Locking Parts have been presented to make easier and faster the mounting of Chain Stretcher Sprockets.*

*Elements set: Exagonal head screw; hole guide bush; self-locking exagonal nut.*

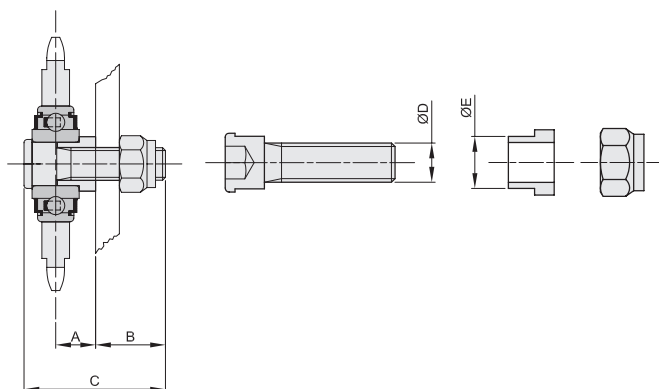

codice	A	B	C	ØD	ØE	Kg
EFT-1	15	25	52	M12	16	0,08
EFT-2	25	28	66	M16	20	0,16