

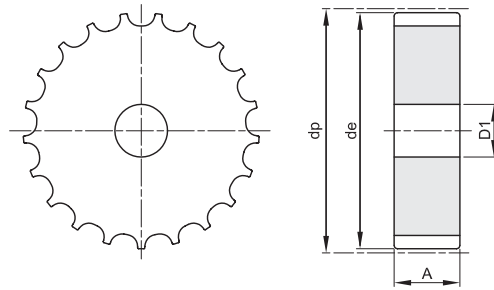

RUEDAS PARA CADENAS DE CHARNELA - DIN 8153

WHEELS FOR TABLE TOP CHAINS - DIN 8153



Material C 43 UNI 7847

Z	passo	de	dp	D1	A	Kg.
15	1"1/2 (38,1)	92,9	93,7	16	43,5	1,86
17	1"1/2 (38,1)	104,7	105,5	16	43,5	2,34
19	1"1/2 (38,1)	116,6	117,3	16	43,5	3,10
21	1"1/2 (38,1)	129,7	129,2	20	43,5	3,79
23	1"1/2 (38,1)	141,6	141,2	20	43,5	4,46
25	1"1/2 (38,1)	153,6	153,2	20	43,5	5,50
27	1"1/2 (38,1)	165,6	165,2	20	43,5	6,31
29	1"1/2 (38,1)	177,7	177,2	20	43,5	7,31
31	1"1/2 (38,1)	189,7	189,3	20	43,5	8,63



PIÑONES TENSORES CON RODAMIENTO Y TORNILLO CHAIN-STRETCHER SPROCKETS WITH BALLS AND FASTENING BOLT

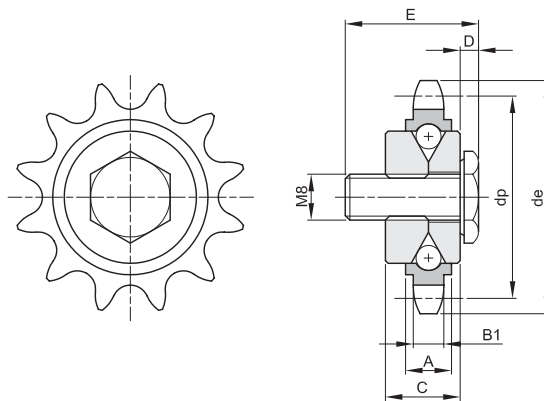

Material C 10 Cementado y Templado

Z	passo	de	dp	A	B1	C	D	E	Kg.
12	3/8" x 5/32"	40	36,80	7	3,5	11,7	3	23	0,06
10	1/2" x 1/8"	46	41,10	7	3	11,7	3	23	0,06
10	1/2" x 3/16"	46	41,10	7	4,5	11,7	3	23	0,07