

1.3 f Características técnicas serie R

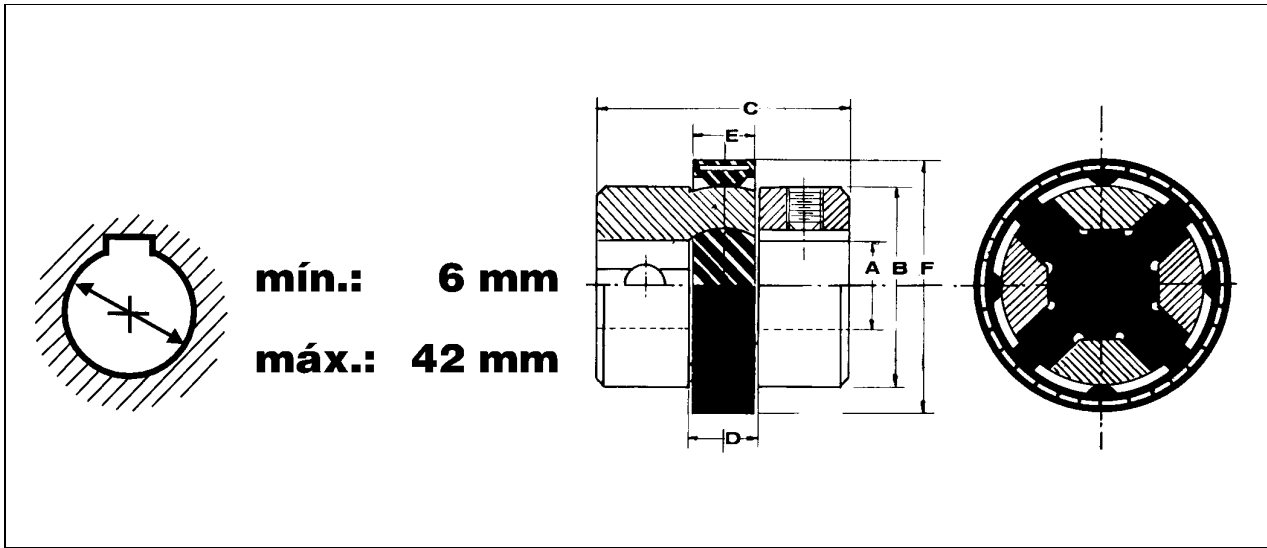

			Serie R			
			1 R	2 R	3 R	4 R
 \varnothing máx. \varnothing mín.	d	mm	16	24	35	42
			6,0	9,8	13,8	18,8
 1 m Nm		Nm	1,69	6,92	13,80	18,80
 /min. máx.		rpm	3500	3000	2500	2000
 ΔK_w		grados	2,0	2,0	1,5	1,5
 ΔK_a		mm \pm	0,5	0,5	1,5	1,5
 ΔK_c		mm \pm	1,5	2,0	2,5	3,0
		kg	0,120	0,370	1,000	2,070
mm \pm	A	mm	16	24	35	42
	B	mm	27,5	42,0	58,5	75,0
	C	mm	38	52	71	89
	D	mm	11	14	22	27
	E	mm	9,5	12,7	19,0	22,5
	F	mm	37	54	70	89