

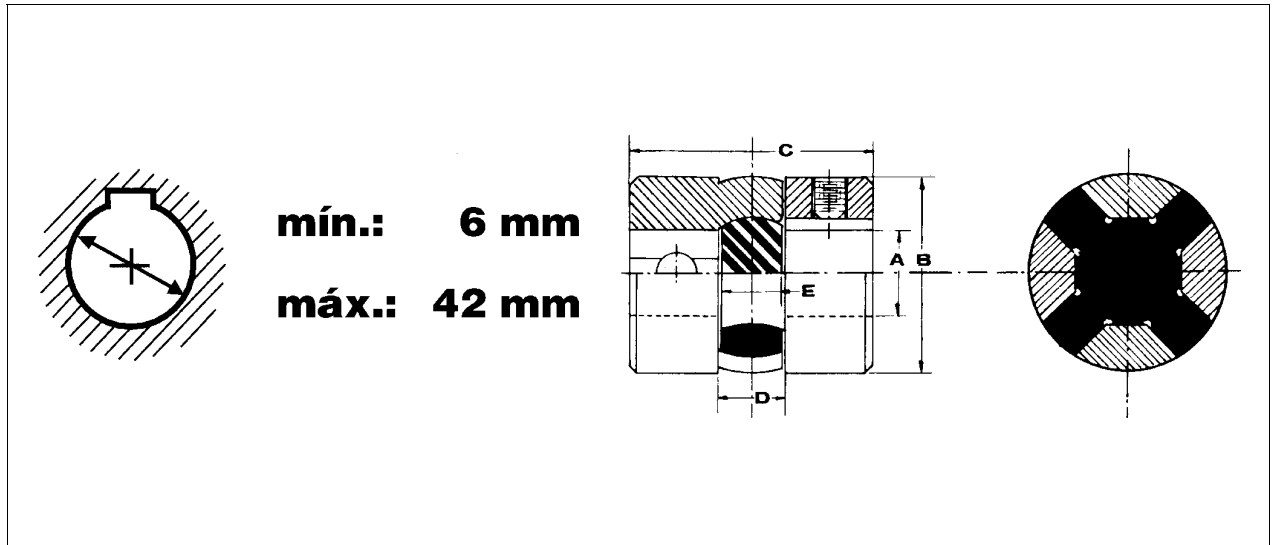

### 1.3 e Características técnicas serie S



**mín.: 6 mm**  
**máx.: 42 mm**

			<b>Serie S</b>			
			<b>1 S</b>	<b>2 S</b>	<b>3 S</b>	<b>4 S</b>
	Ø máx.	<b>mm</b>	16	24	35	42
	Ø mín.		6,0	9,8	13,8	18,8
		<b>Nm</b>	1,28	4,35	17,90	33,50
	/min. máx.	<b>rpm</b>	6000	5500	4500	4000
		<b>grados</b>	3	3	2	2
		<b>mm ±</b>	1	1	2	2
		<b>mm ±</b>	1,5	2,0	2,5	3,0
		<b>kg</b>	0,110	0,350	0,820	2,050
<b>mm ±</b>	<b>A</b>	<b>mm</b>	16	24	35	42
	<b>B</b>	<b>mm</b>	27,5	42,0	58,5	75,0
	<b>C</b>	<b>mm</b>	38	52	71	89
	<b>D</b>	<b>mm</b>	11	14	22	26
	<b>E</b>	<b>mm</b>	9,5	12,7	19,0	22,5